

DANIELS FOOD EQUIPMENT

DVTS 500 HOSTILE ENVIRONMENT TUMBLER

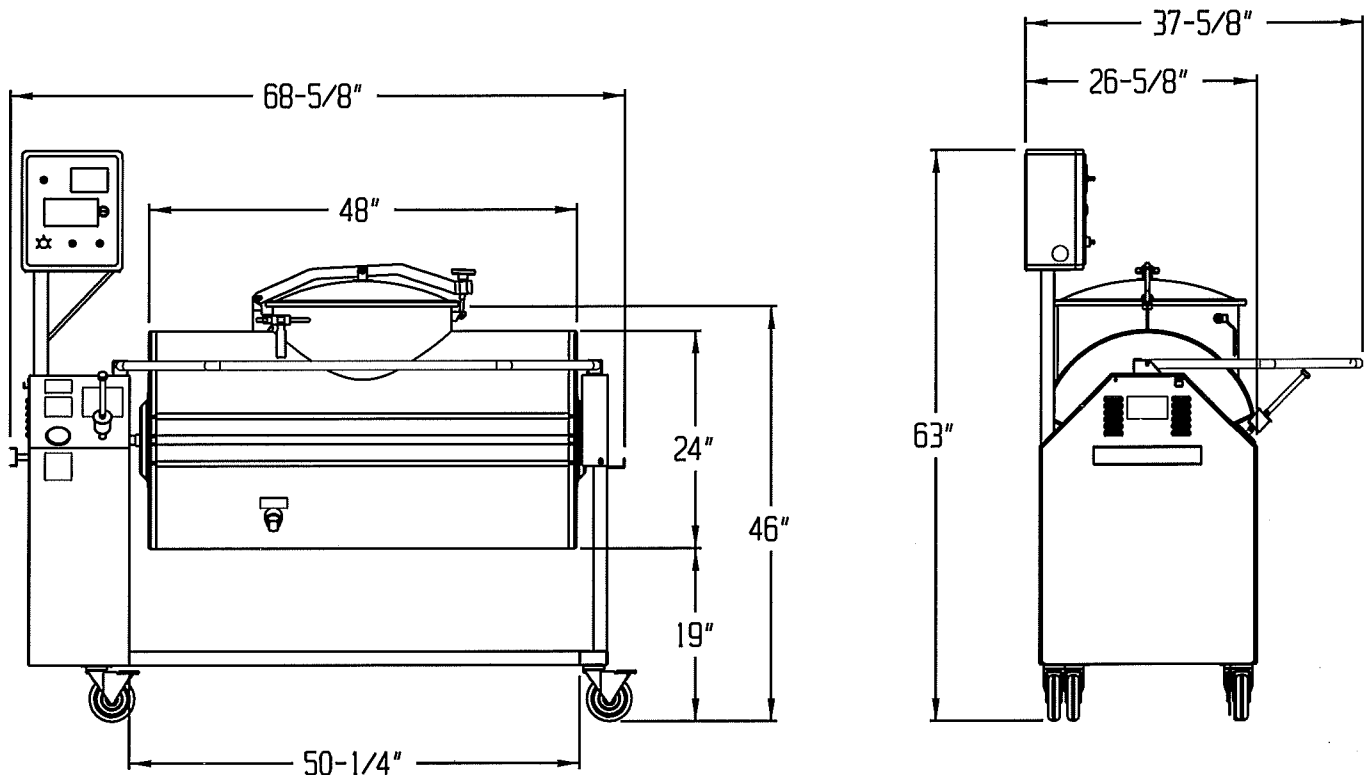

SPECIFICATIONS

TOTAL POWER INPUT:	12-1/2 AMP, 115 VOLT, 60 HZ AC, 1 PHASE
TUMBLER DRIVE:	VARIABLE SPEED CONTROL, FWD/OFF/REV
DRIVE MOTOR:	1/2 HP
VACUUM PUMP:	1/4 HP 115 VOLT, 60 HZ, 1 PHASE
TOUCH SCREEN TIMER:	HOURS, MINUTES, BATCH COUNTING
ELECTRONIC CONTROLS:	TUMBLER SPEED-ADJUSTABLE 0-15 RPM "JOG"- "RUN" TOGGLE SWITCH, "FWD"- "REV" TOGGLE SWITCH, "START"- "STOP" TOGGLE SWITCH, VACUUM PUMP "START"- "STOP" TOGGLE SWITCH
MAXIMUM CAPACITY:	550-LBS.
WEIGHT:	420-LBS. (NET)
FEATURES:	DOUBLE ROW CHAIN AND SPROCKETS, CENTER SHAFT THROUGH TANK OR END SHAFTS

DANIELS FOOD EQUIPMENT

310 NORTH CLAYBORN AVE. PARKERS PRAIRIE, MN. 56361 PHONE: (218) 338-5000 FAX (218) 338-5909.

WEB: www.danielsfood.com

E-MAIL: danielsfood@midwestinfo.net

1/17/2020