

# DANIELS FOOD EQUIPMENT

## DFS-50 HYDRAULIC STUFFING MACHINE

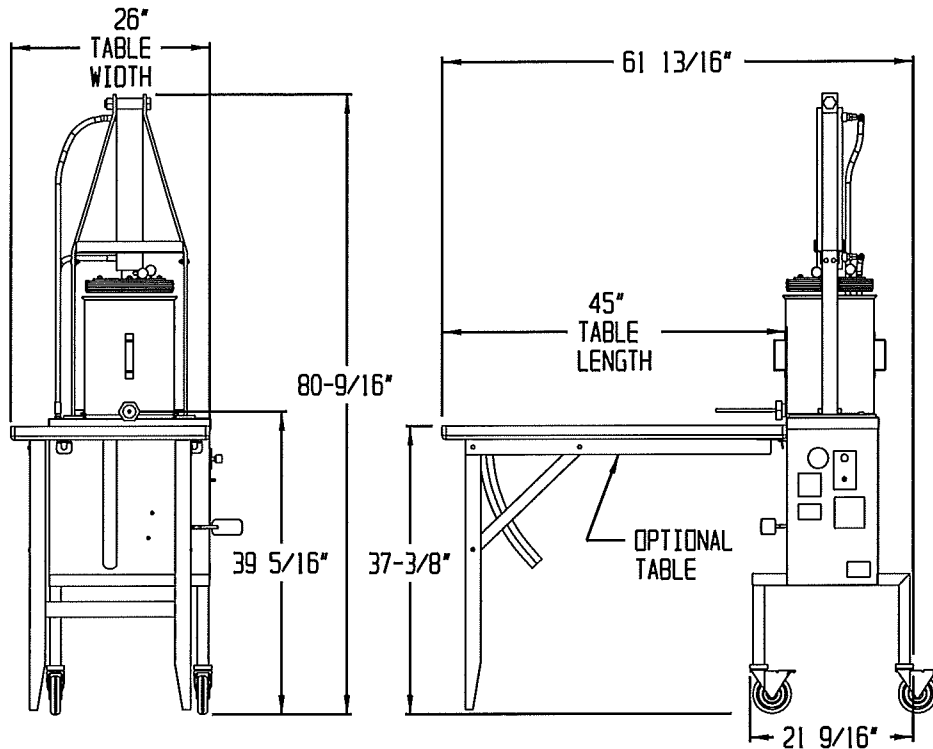

### SPECIFICATIONS

<b>PRODUCT CYLINDER:</b>	STAINLESS STEEL 50 LBS. CAPACITY
<b>EXTRUDING NOZZLES: (STANDARD)</b>	7/16" OUTSIDE DIAMETER * P/N 45026-01 1/2" OUTSIDE DIAMETER * P/N 45026-02 3/4" OUTSIDE DIAMETER * P/N 45026-04 1-1/4" OUTSIDE DIAMETER * P/N 45026-06 *SHIPPED WITH MACHINE
<b>EXTRUDING NOZZLES: (OPTIONAL)</b>	5/8" OUTSIDE DIAMETER P/N 45026-03 1" OUTSIDE DIAMETER P/N 45026-05 1-1/2" OUTSIDE DIAMETER P/N 45026-07
<b>PISTON MATERIAL:</b>	STAINLESS STEEL & PLASTIC
<b>OIL RESERVOIR:</b>	8-QUART CAPACITY, SELF-CONTAINED
<b>MOTOR:</b>	3/4 HP, 115 VOLT, 60Hz, 1 PHASE, 10.8 AMPS
<b>HYDRAULIC OIL:</b>	INDOL NZ ISO 46MV OR EQUIVALENT
<b>WEIGHT:</b>	263 LBS. (WITH OIL)

### DANIELS FOOD EQUIPMENT

310 NORTH CLAYBORN AVENUE, PARKERS PRAIRIE, MN 56361 PHONE: (218) 338-5000 FAX (218) 338-5909

WEB: [www.danielsfood.com](http://www.danielsfood.com)

E-MAIL: [danielsfood@midwestinfo.net](mailto:danielsfood@midwestinfo.net)

1/17/2020