

# **DANIELS FOOD EQUIPMENT**

## **AFMG 532 MIXER GRINDER**

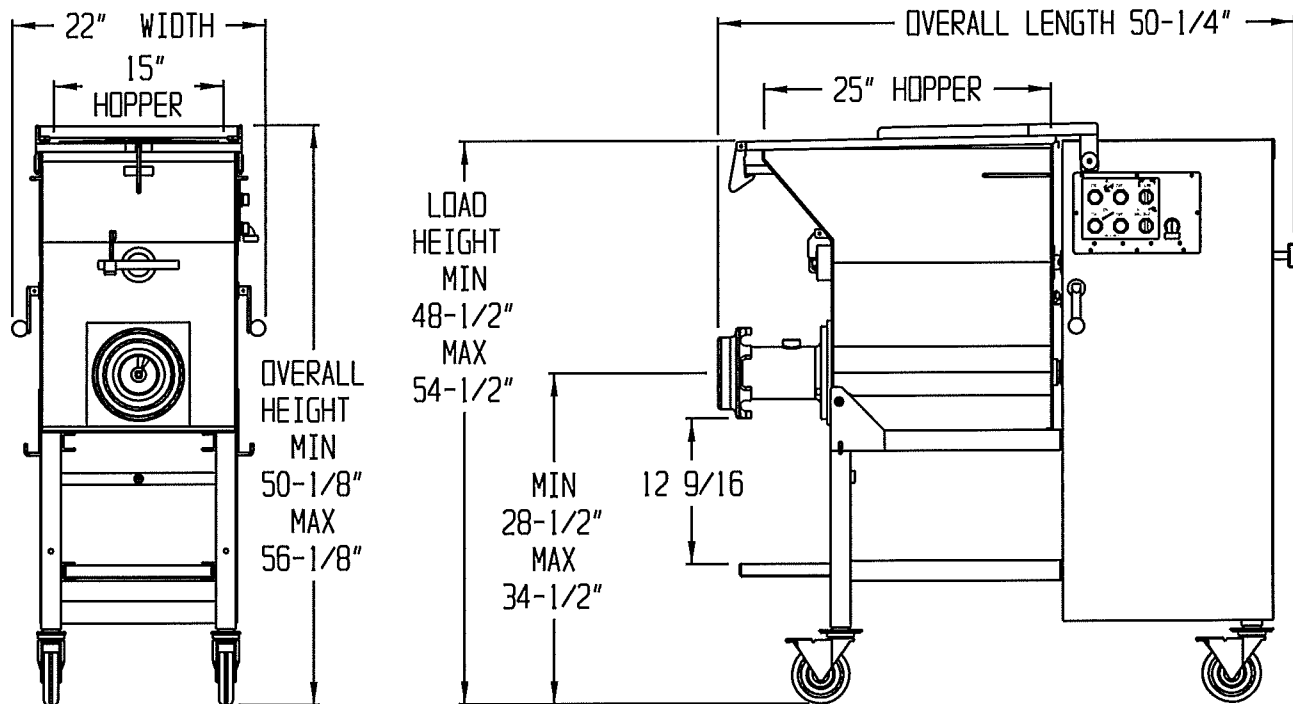

### **SPECIFICATIONS**

- STANDARD MOTOR:** GRINDER; 230 VOLT, 13.4 AMP, 1725 RPM, 60 Hz, 5 HP, 3 PH.  
MIXER; 230 VOLT, 3.0 AMP, 1725 RPM, 60 Hz, 3/4 HP, 3 PH.
- OPTIONAL MOTOR:** GRINDER; 208/460 VOLT, 13.9/6.7 AMP, 1725 RPM, 60 Hz, 3 PH.  
MIXER; 208/460 VOLT, 3.2/1.5 AMP, 1725 RPM, 60 Hz, 3 PH.
- CONSTRUCTION:** ALL STAINLESS STEEL CONSTRUCTION,  
100 LBS. CAPACITY, REMOVABLE PADDLE, STAINLESS STEEL  
HOPPER COVER, ADJUSTABLE SHELF.
- CONTROLS:** MIX ON/OFF - BOTH DIRECTIONS, GRIND ON/OFF,  
HAND OR FOOT CONTROL
- WEIGHT:** 690 LBS. SHIPPING INFO: 740 LBS. SIZE: 36" X 60" X 48" HIGH
- OUTPUT:** UP TO 100 LBS PER MINUTE WITH 3/8" PLATE

### **DANIELS FOOD EQUIPMENT**

310 NORTH CLAYBORN AVE P.O. BOX 341, PARKERS PRAIRIE, MN. 56361

PHONE: (218) 338-5000 FAX (218) 338-5909.

WEB: [www.danielsfood.com](http://www.danielsfood.com) E-MAIL: [danielsfood@midwestinfo.net](mailto:danielsfood@midwestinfo.net)