

# **DANIELS FOOD EQUIPMENT**

## **DVTS 200 TUMBLER**

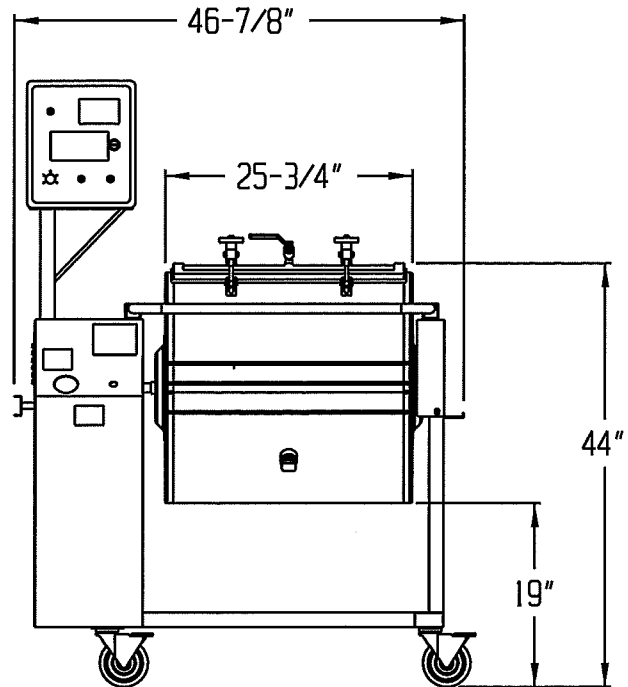
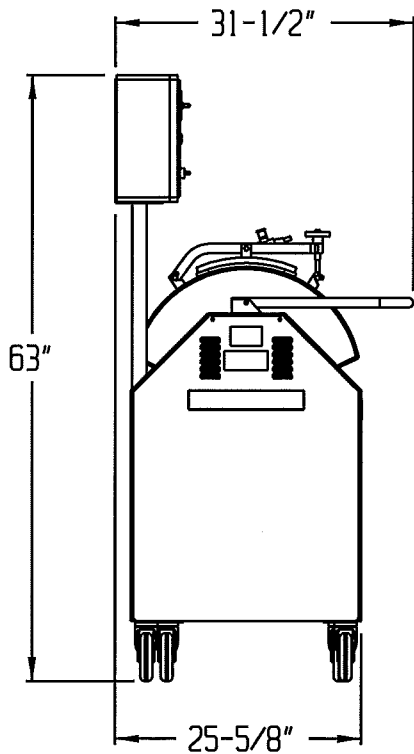

### **SPECIFICATIONS**

<b>TOTAL POWER INPUT:</b>	12-1/2 AMP, 115 VOLT, 60 HZ AC, 1 PHASE
<b>TUMBLER DRIVE:</b>	VARIABLE SPEED CONTROL, FWD/OFF/REV
<b>DRIVE MOTOR:</b>	1/2 HP
<b>VACUUM PUMP:</b>	1/4 HP 115 VOLT, 60 HZ, 1 PHASE
<b>TOUCH SCREEN TIMER:</b>	HOURS, MINUTES, BATCH COUNTING
<b>ELECTRONIC CONTROLS:</b>	TUMBLER SPEED-ADJUSTABLE 0-15 RPM "JOG"- "RUN" TOGGLE SWITCH, "FWD"- "REV" TOGGLE SWITCH "START"- "STOP" TOGGLE SWITCH VACUUM PUMP "START"- "STOP" TOGGLE SWITCH
<b>MAXIMUM CAPACITY:</b>	250-LBS.
<b>WEIGHT:</b>	360-LBS. (NET)
<b>OPTIONAL POWER:</b>	220 VOLT, 60 Hz, 1 PHASE, 6.3 AMP 220 VOLT, 50 Hz, 1 PHASE, 6.3 AMP 380 VOLT, 50 Hz, 1 PHASE, 4.2 AMP

### **DANIELS FOOD EQUIPMENT**

310 NORTH CLAYBORN AVE. PARKERS PRAIRIE, MN. 56361 PHONE: (218) 338-5000 FAX (218) 338-5909.  
WEB: [www.danielsfood.com](http://www.danielsfood.com) E-MAIL: [danielsfood@midwestinfo.net](mailto:danielsfood@midwestinfo.net)