

DANIELS FOOD EQUIPMENT

DVTS 15 VACUUM TUMBLER

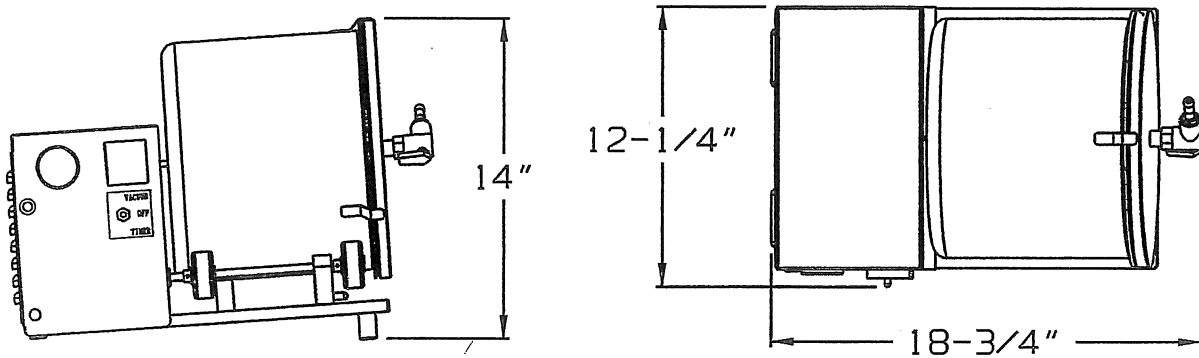

SPECIFICATIONS

POWER SUPPLY:	15 AMP, 120 VOLT, 60 Hz CIRCUIT, 1 PHASE, 3.0 AMPS MAX
TUMBLER SPEED:	10-1/2 RPM
VACUUM PUMP:	0 – 22 (IN. HG.)
TIMER:	LED READ OUT IN HOURS AND MINUTES
FEATURES:	VACUUM GAUGE, TIMER, TUMBLE / VACUUM – TOGGLE SWITCH
CAPACITY:	15-LBS. MAXIMUM, 12.5 LBS. TUMBLE CAPACITY
WEIGHT:	26-LBS. (NET)
STANDARD MOTOR:	120 VOLT, 60 Hz, 1 PHASE, 1/100 HP & 1/25 HP, 3.0AMP & 1.7AMP
OPTIONAL MOTORS:	220 VOLT, 60 Hz, 1 PHASE, 1/100HP & 1/25 HP, 0.8AMP & 0.9AMP 220 VOLT, 50 Hz, 1 PHASE, 1/100HP & 1/25 HP, 0.8AMP & 0.9AMP

DANIELS FOOD EQUIPMENT

310 NORTH CLAYBORN AVE. PARKERS PRAIRIE, MN. 56361 PHONE: (218) 338-5000 FAX (218) 338-5909.
WEB: www.danielsfood.com E-MAIL: danielsfood@midwestinfo.net