

DANIELS FOOD EQUIPMENT

DMX and DMX QUAD 500 MIXER

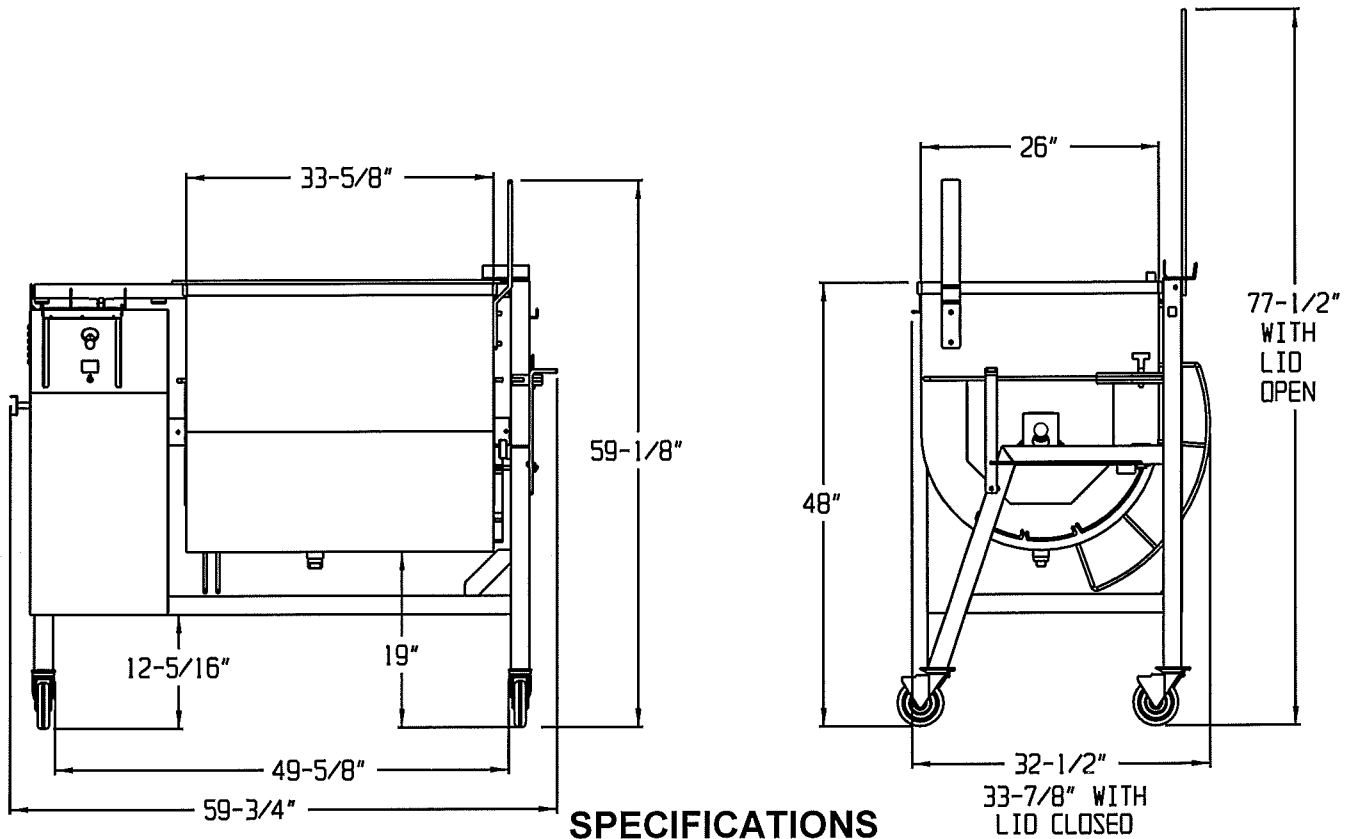

MOTOR:	STANDARD: 5 HP, 3 PHASE, 230 VOLT, 60 Hz, 12.6 AMP OPTIONAL: 5 HP, 3 PHASE, 208/460 VOLT, 60 Hz, 13.93/6.3AMP
PADDLE RPM:	DMX: 24-1/3 RPM DMX QUAD: INNER 28-3/4 RPM, OUTER 28-3/4 RPM
TIMER:	LED READOUT – SECONDS and MINUTES
DIRECTION CONTROL:	FORWARD-STOP-REVERSE
HOPPER CAPACITY:	500-LBS
HOPPER CONSTRUCTION:	12 GA STAINLESS STEEL, 110° DUMPING, REMOVABLE PADDLE, CLEANOUT DRAIN ON BOTTOM, TRANSPARENT COVER WITH SAFETY LOCKOUT.
FRAME:	11 GA STAINLESS STEEL TUBING, OPEN UNDER HOPPER FOR EASY DUMPING, LOCKING SWIVEL CASTERS.
DUMP HEIGHT:	12-7/8"
WEIGHT:	DMX: 645-LBS, SHIPPING INFO: 720-LBS, SIZE: 36" X 60" X 53" HIGH DMX QUAD: 685-LBS, SHIPPING INFO: 760-LBS, SIZE: 36" X 60" X 53" HIGH

DANIELS FOOD EQUIPMENT

310 NORTH CLAYBORN AVE. PARKERS PRAIRIE, MN. 56361 PHONE: (218) 338-5000 FAX (218) 338-5909

WEB: www.danielsfood.com

E-MAIL: danielsfood@midwestinfo.net