

DANIELS FOOD EQUIPMENT

DMX AND DMX QUAD 200 MIXER

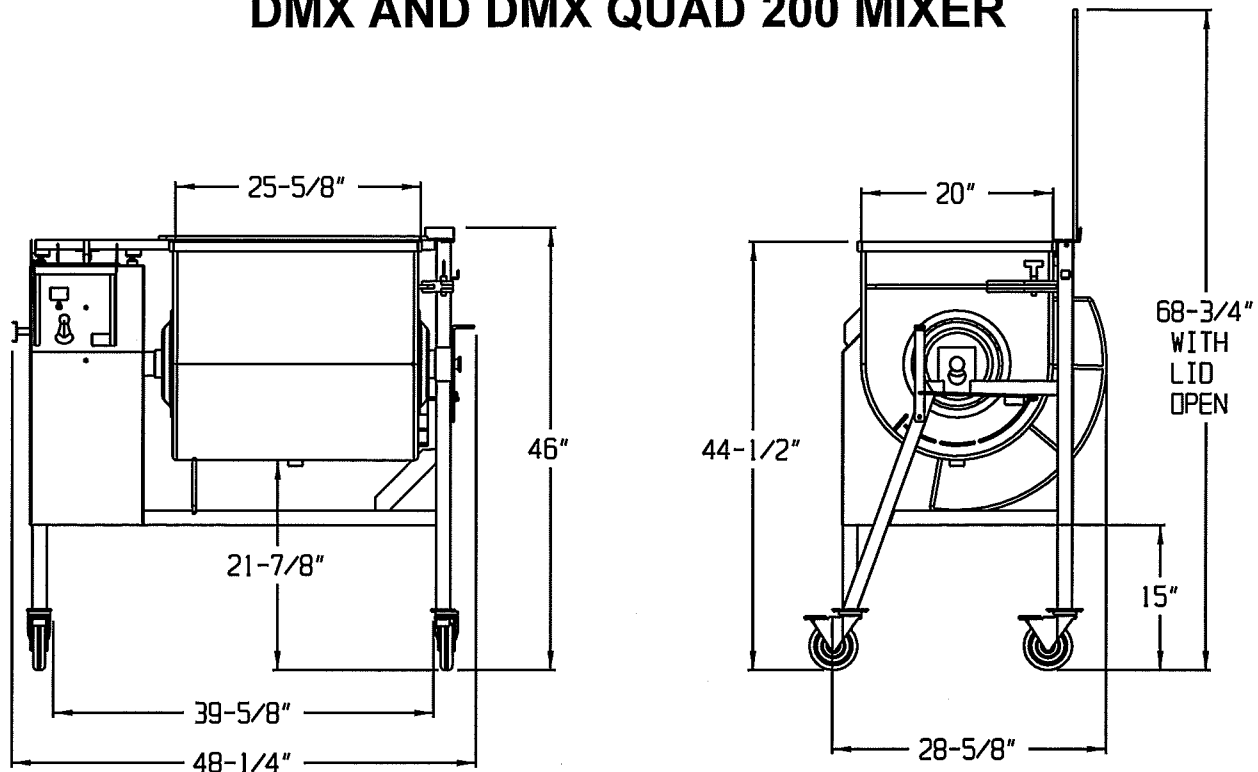

SPECIFICATIONS

MOTOR:	STANDARD: 1-1/2 HP, 3 PH, 230 VOLT, 60 Hz, 5.0 AMP OPTIONAL: 1-1/2 HP, 3 PH, 208/460 VOLT, 60 Hz, 5.2/2.5 AMP OPTIONAL: 2 HP, 1 PH, 115 VOLT, 60 Hz, 20 AMP OPTIONAL: 2 HP, 1 PH, 230VOLT, 60 Hz, 10 AMP
PADDLE RPM:	DMX: 24 RPM DMX QUAD: INNER 24 RPM, OUTER 22-1/2 RPM
TIMER:	LED READOUT – SECONDS and MINUTES
DIRECTION CONTROL:	FORWARD-STOP-REVERSE
HOPPER CAPACITY:	200-LBS
HOPPER CONSTRUCTION:	12 GA STAINLESS STEEL, 110° DUMPING, REMOVABLE PADDLE, CLEANOUT DRAIN ON BOTTOM, TRANSPARENT COVER WITH SAFETY LOCKOUT.
FRAME:	11 GA STAINLESS STEEL TUBING, OPEN UNDER HOPPER FOR EASY DUMPING, LOCKING SWIVEL CASTERS.
DUMP HEIGHT:	16-1/4"
WEIGHT:	DMX: 375-LBS, SHIPPING INFO: 425-LBS, SIZE: 52" X 32" X 48" HIGH DMX QUAD: 395-LBS, SHIPPING INFO: 445-LBS, SIZE: 52" X 32" X 48" HIGH

DANIELS FOOD EQUIPMENT

310 NORTH CLAYBORN AVE. PARKERS PRAIRIE, MN. 56361 PHONE: (218) 338-5000 FAX (218) 338-5909

WEB: www.danielsfood.com

E-MAIL: danielsfood@midwestinfo.net

1/17/2020