

# DMX QUAD 100 HD SPECIFICATIONS

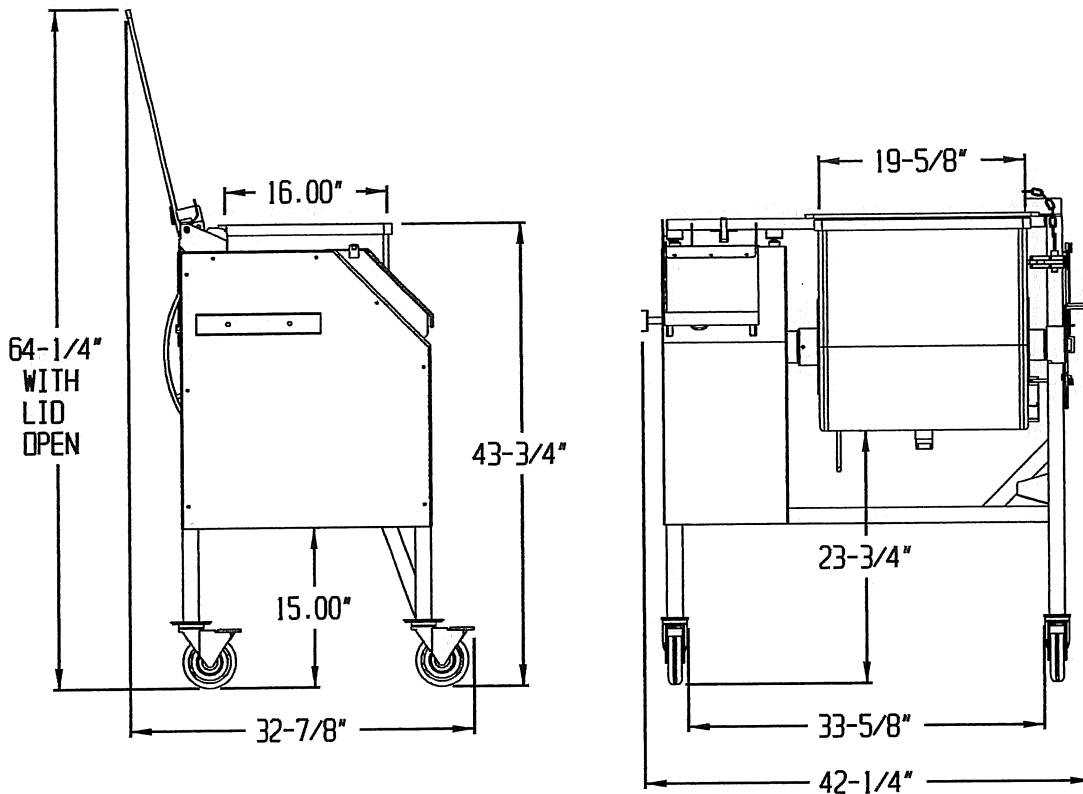

- MOTOR:** STANDARD: 1-1/2 HP, 3 PH, 230 V, 60 Hz, 5.0 AMP  
 OPTIONAL: 2 HP, 1 PH, 115/230 V, 60 Hz, 20/10 AMP  
 OPTIONAL: 1-1/2 HP, 3 PH, 208/460 V, 60 Hz, 5.2/2.5 AMP
- PADDLE RPM:** INNER: 24 RPM OUTER: 22-1/2 RPM
- TIMER:** LED READOUT – MINUTES / SECONDS
- DIRECTIONAL CONTROL:** FORWARD – STOP – REVERSE
- HOPPER CAPACITY:** 100 LBS
- HOPPER CONSTRUCTION:** 12 GA STAINLESS STEEL, 110° DUMPING, REMOVABLE PADDLE, CLEANOUT DRAIN, TRANSPARENT COVER WITH SAFETY LOCKOUT
- FRAME:** 11 GA STAINLESS STEEL TUBING, OPEN UNDER HOPPER FOR EASY DUMPING, LOCKING SWIVEL CASTERS
- DUMP HEIGHT:** 20-5/8"
- WEIGHT:** 335 LBS
- SHIPPING INFO:** 360 LBS, 52" X 32" X 48" HIGH