

DANIELS FOOD EQUIPMENT

DMX and DMX QUAD 100 MIXER

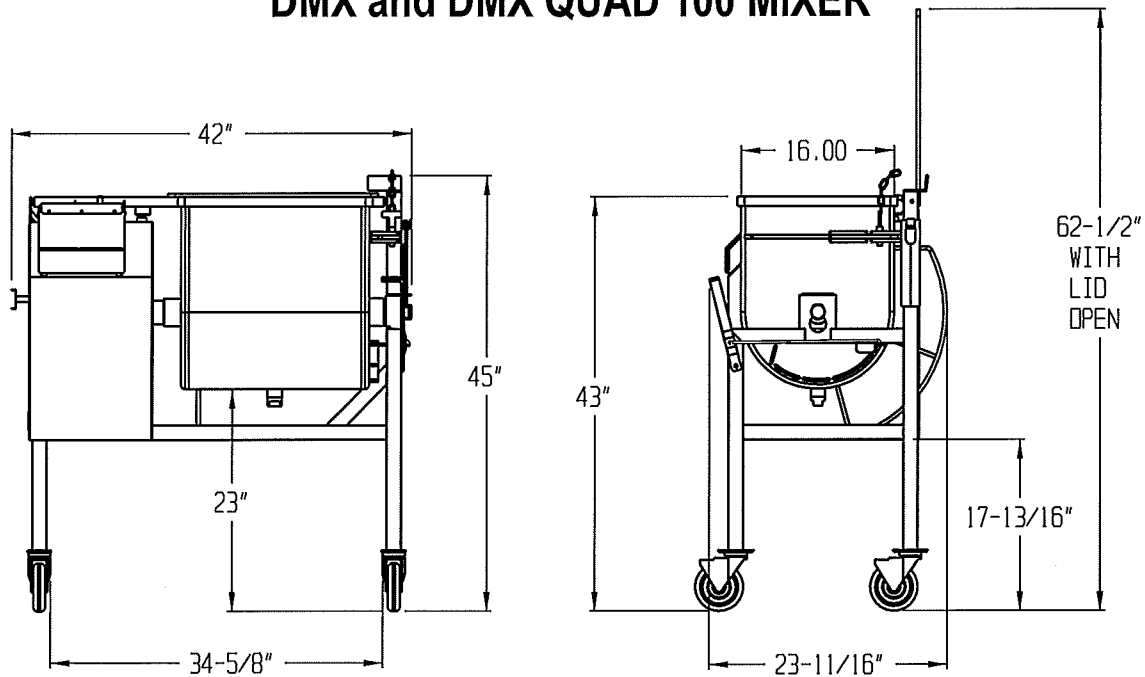

SPECIFICATIONS

MOTOR DMX:	STANDARD: 3/4 HP, 1 PH, 115 VOLT, 60 Hz 10.8 AMP OPTIONAL: 3/4 HP, 1 PH, 208/230 VOLT, 60 Hz, 5.5/5.4 AMP OPTIONAL: 3/4 HP, 1 PH, 115/230 VOLT, 50 Hz, 11.8/5.9 AMP OPTIONAL: 3/4 HP, 3 PH, 208/230/460 VOLT, 60 Hz, 3.2/2.8/1.4 AMP OPTIONAL: 3/4 HP, 3 PH, 220/380/460 VOLT, 50 Hz, 1.8/1.85/1.15 AMP
MOTOR DMX QUAD:	STANDARD: 1HP, 1 PH, 115 VOLT, 60 Hz, 12.8 AMP OPTIONAL: 1 HP, 1 PH, 208/230 VOLT, 60 Hz, 7.1/6.4 AMP OPTIONAL: 1 HP, 3 PH, 208/230/460 VOLT, 60 Hz, 4.0/3.6/1.8 AMP OPTIONAL: 1 HP, 1 PH, 115/230 VOLT, 50 Hz, 12.8/6.4 AMP
PADDLE RPM:	DMX: 30-3/4 RPM DMX QUAD: INNER 30-3/4 RPM, OUTER 28-3/4 RPM
TIMER:	LED READOUT – SECONDS and MINUTES
DIRECTION CONTROL:	FORWARD-STOP-REVERSE
HOPPER CAPACITY:	100-LBS
HOPPER CONSTRUCTION:	12 GA STAINLESS STEEL, 110° DUMPING, REMOVABLE PADDLE, CLEANOUT DRAIN ON BOTTOM, TRANSPARENT COVER WITH SAFETY LOCKOUT.
FRAME:	11 GA STAINLESS STEEL TUBING, OPEN UNDER HOPPER FOR EASY DUMPING, LOCKING SWIVEL CASTERS.
DUMP HEIGHT:	20-1/2"
WEIGHT:	DMX: 280 LBS, SHIPPING INFO: 335-LBS, SIZE: 52" X 32" X 48" HIGH DMX QUAD: 335 LBS, SHIPPING INFO: 360-LBS, SIZE: 52" X 32" X 48" HIGH

DANIELS FOOD EQUIPMENT

310 NORTH CLAYBORN AVE. PARKERS PRAIRIE, MN. 56361 PHONE: (218) 338-5000 FAX: (218) 338-5909

WEB: www.danielsfood.com E-MAIL: danielsfood@midwestinfo.net

1/16/2020