

# **DANIELS FOOD EQUIPMENT**

## **DVTS R2-50 TUMBLER**

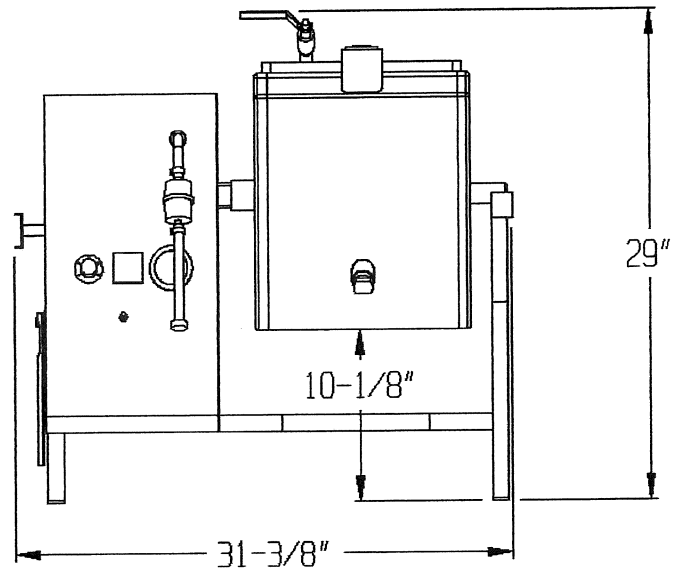
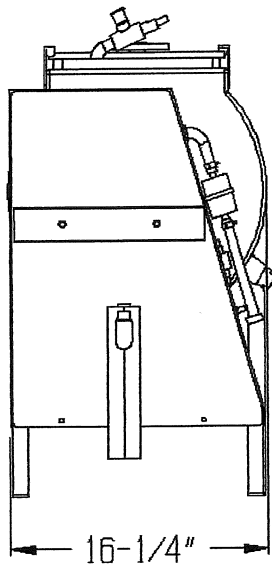

### **SPECIFICATIONS**

<b>TOTAL POWER INPUT:</b>	<b>115 VOLT, 60 Hz, 1 PHASE CIRCUIT, 4 AMP TOTAL</b>
<b>TUMBLER DRIVE:</b>	<b>ELECTRONIC SPEED CONTROL INPUT 115 V AC 60Hz, 1PH</b>
<b>TUMBLER DRIVE MOTOR:</b>	<b>120:1 RATIO, 1/8 HP, 130 VOLTS DC</b>
<b>VACUUM PUMP:</b>	<b>1/8 HP, 115 AC VOLTS, 3.6 AMPS, 60Hz, 1PHASE</b>
<b>TIMER:</b>	<b>DIGITAL - HOURS AND MINUTES</b>
<b>VACUUM GAUGE:</b>	<b>(RANGE) 0 TO 30 INCHES OF MERCURY</b>
<b>ELECTRONIC CONTROLS:</b>	<b>TUMBLER SPEED -ADJUSTABLE 0 TO 16 RPM, TIMER "START -STOP" ,VACUUM PUMP "STOP"- "START" TOGGLE</b>
<b>MAXIMUM CAPACITY:</b>	<b>50-LBS.</b>
<b>MATERIAL:</b>	<b>300 SERIES STAINLESS STEEL TUMBLER, FRAME AND</b>
<b>WEIGHT:</b>	<b>112-LBS. (NET) 132-LBS (SHIPPING WEIGHT)</b>
<b>OPTIONAL POWER INPUT:</b>	<b>220 VOLTS, 60Hz, 1 PHASE, 2AMP 220 VOLTS, 50Hz, 1 PHASE, 2 AMP</b>

### **DANIELS FOOD EQUIPMENT**

**310 NORTH CLAYBORN AVENUE P.O. BOX 341 PARKERS PRAIRIE, MN. 56361**

**PHONE: (218) 338-5000 FAX (218) 338-5909.**

**WEB: [www.danielsfood.com](http://www.danielsfood.com)**

**E-MAIL: [danielsfood@midwestinfo.net](mailto:danielsfood@midwestinfo.net)**