

DANIELS FOOD EQUIPMENT

DG 1056 FLAT TOP GRINDER

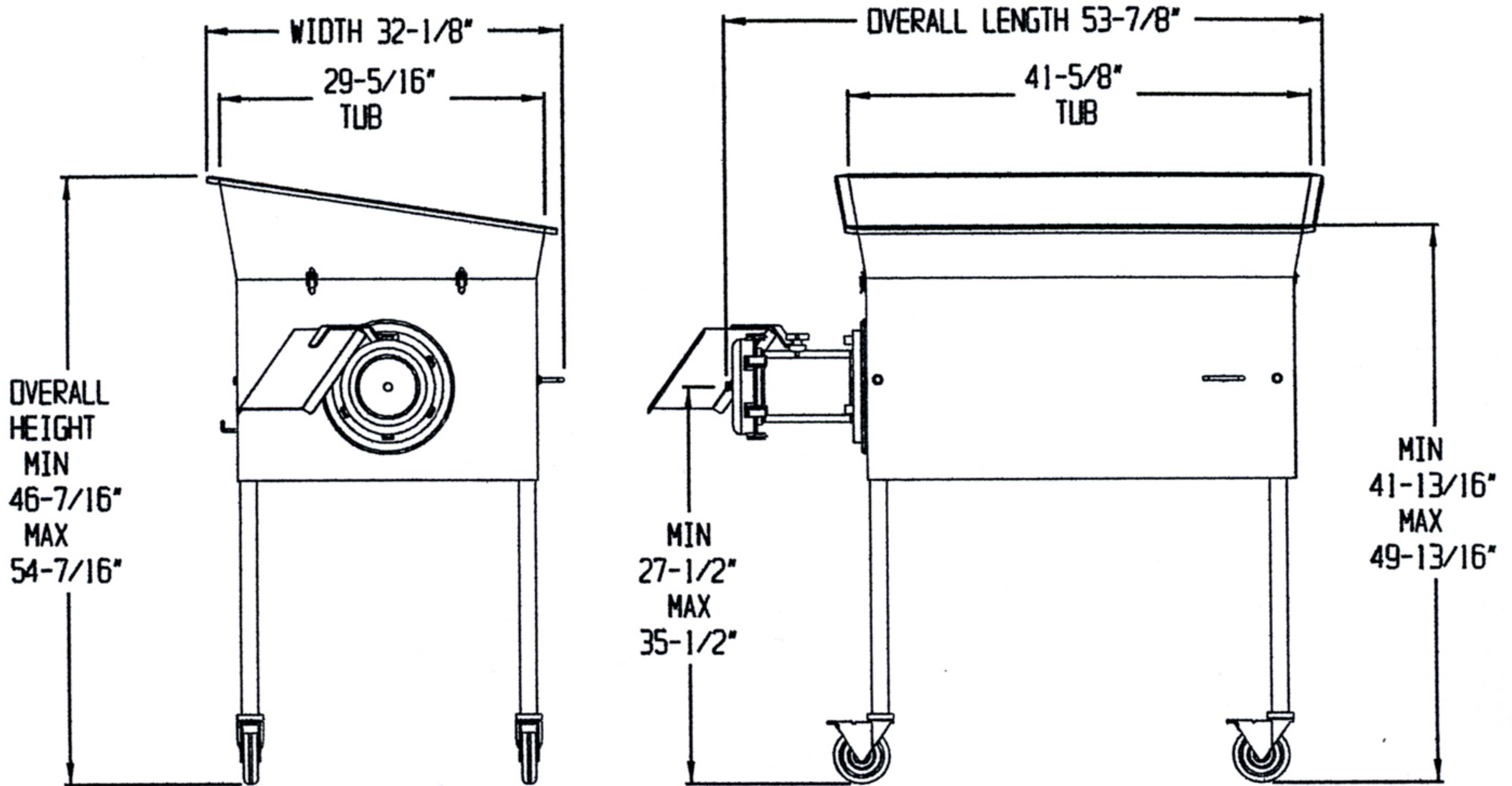

SPECIFICATIONS

- STANDARD:** 230 VOLT, 30 AMP, 60 Hz, 10 HP, 3 PHASE.
- OPTIONAL:** 208 VOLT, 3 PHASE, 60 Hz, AMP DRAW 32.2 AMP
460 VOLT, 3 PHASE, 60 Hz, AMP DRAW 14.8 AMP
- CONSTRUCTION:** HEAVY GAUGE STAINLESS STEEL CONSTRUCTION,
175 LB. CAPACITY, REMOVABLE AUGER, STAINLESS
STEEL TUB WITH SAFETY LOCKOUT.
- WORKING CAPACITY:** 175-LBS.
- WEIGHT:** 505 LBS. NET, 580 LBS. SHIPPING WEIGHT.
- OUTPUT:** UP TO 200-300 LBS. PER MINUTE WITH 3/8" PLATE,
DEPENDING ON PRODUCT.

DANIELS FOOD EQUIPMENT

310 NORTH CLAYBORN AVE. PARKERS PRAIRIE, MN. 56361 PHONE: (218) 338-5000 FAX: (218) 338-5909.

WEB: www.danielsfood.com

E-MAIL: danielsfood@midwestinfo.net